

CRAFTSMAN SAWHORSES

Materials List:

Qty./ Dim./ Length

4 4x6 4'

4 4x4 4'

1 2x4 6' Full Dimension

1 2x2 2' Hardwood for wedges

Tools Needed

-Table Saw

-Miter Saw

-Bandsaw

-Thickness Planer

-Router

-Drill

-Hand Tools

Notes:

Due to the style of joinery used in this project, Glue is not necessary (if joints are tight). But glue can be used if desired. I recommend using semi-hard or hardwood for these sawhorses.

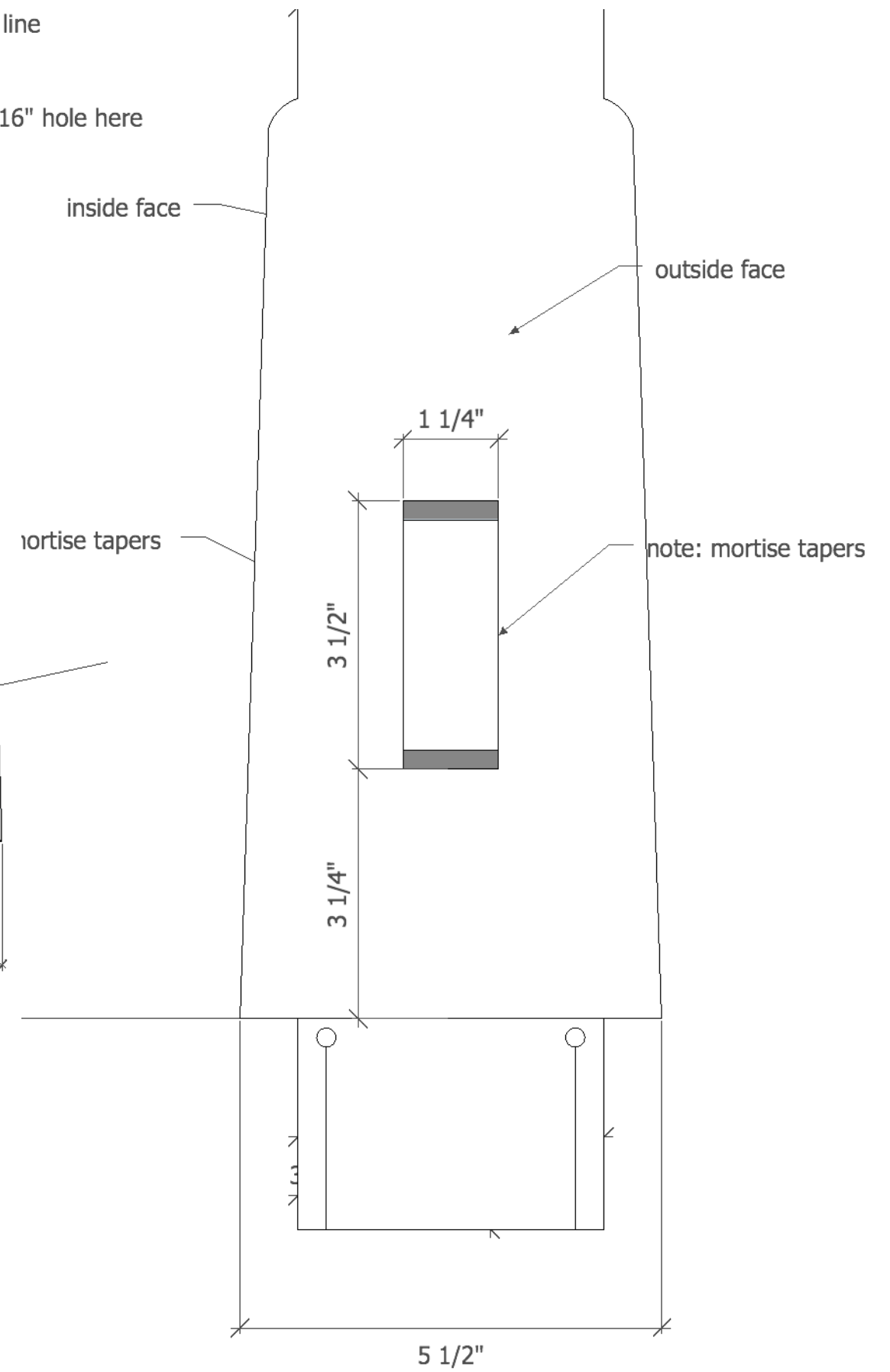
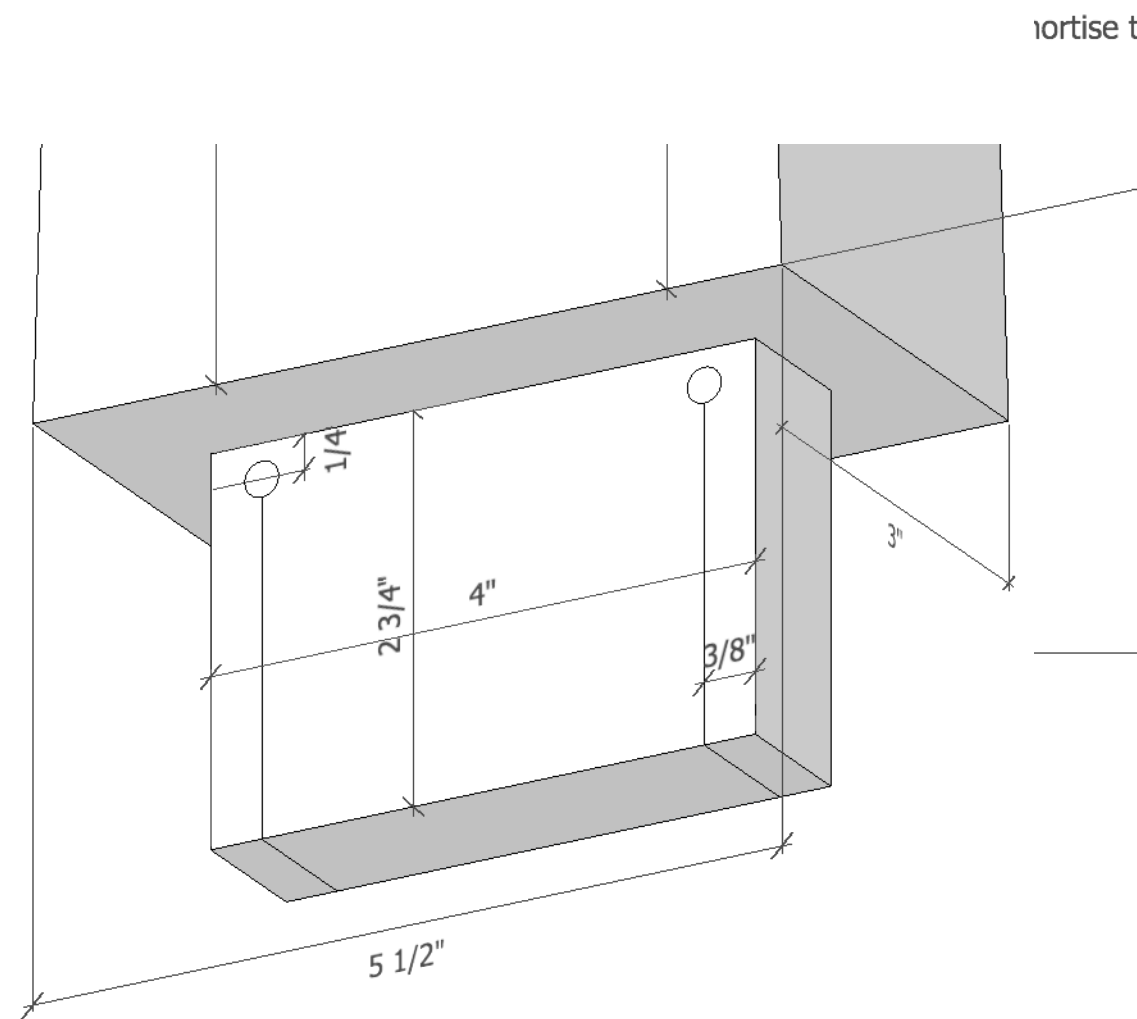
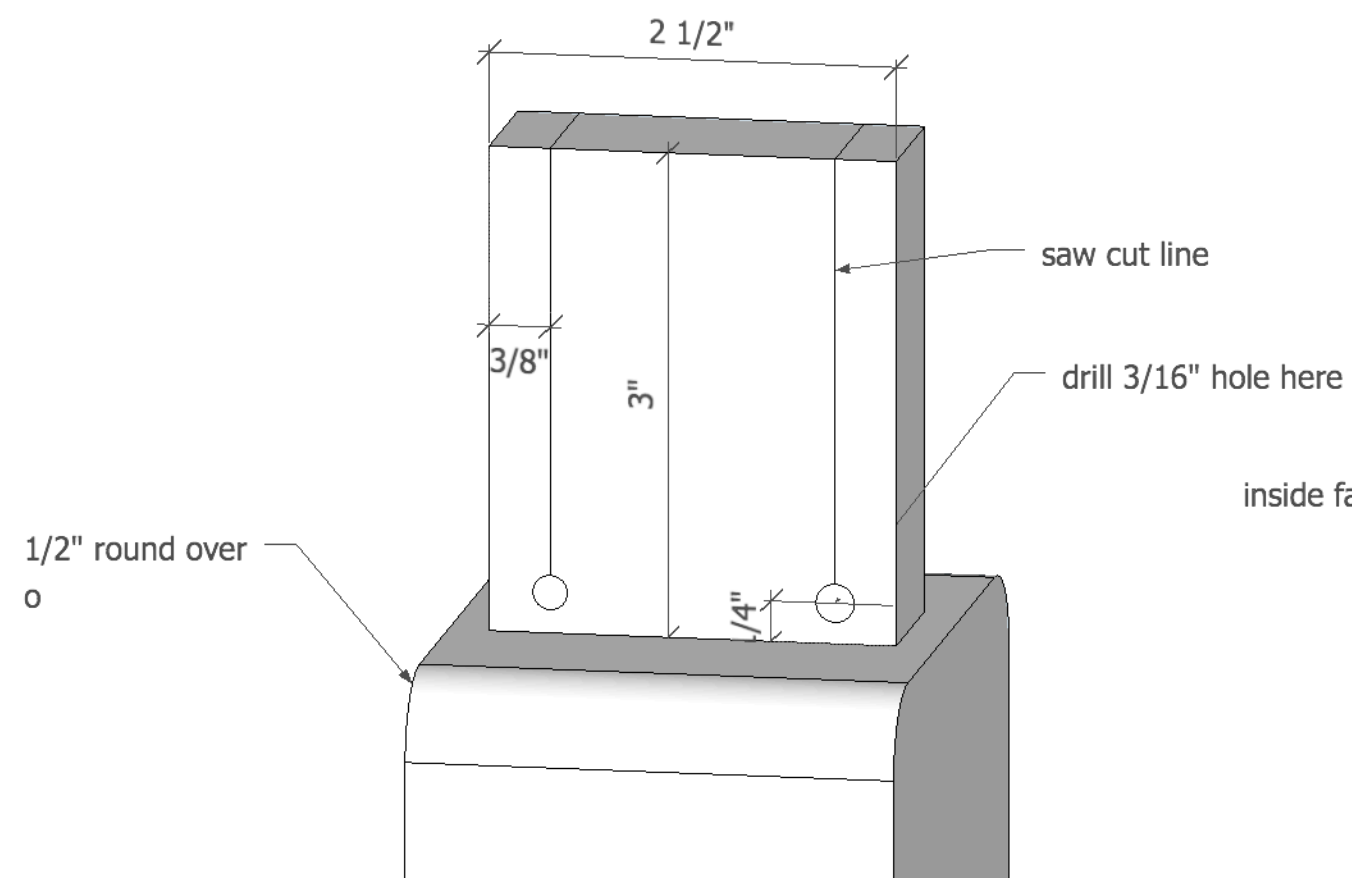
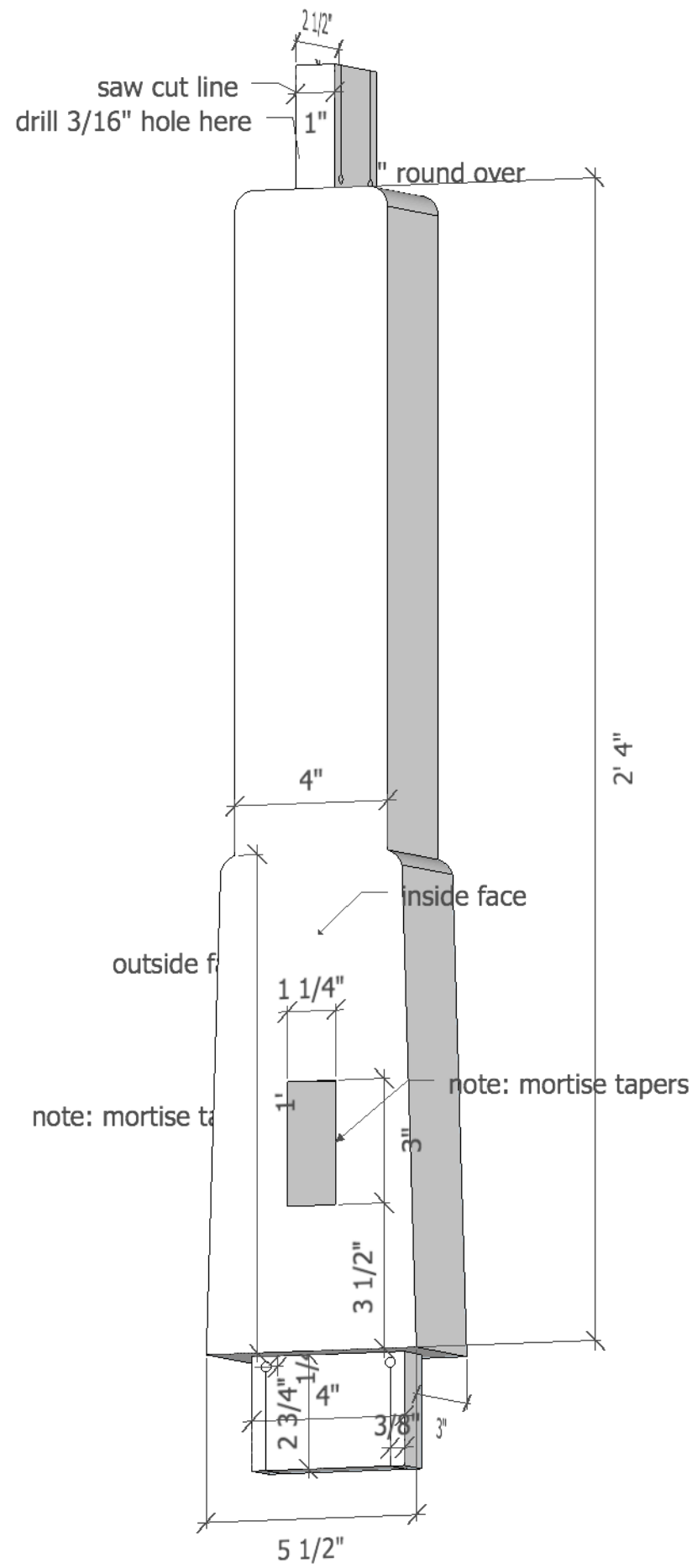

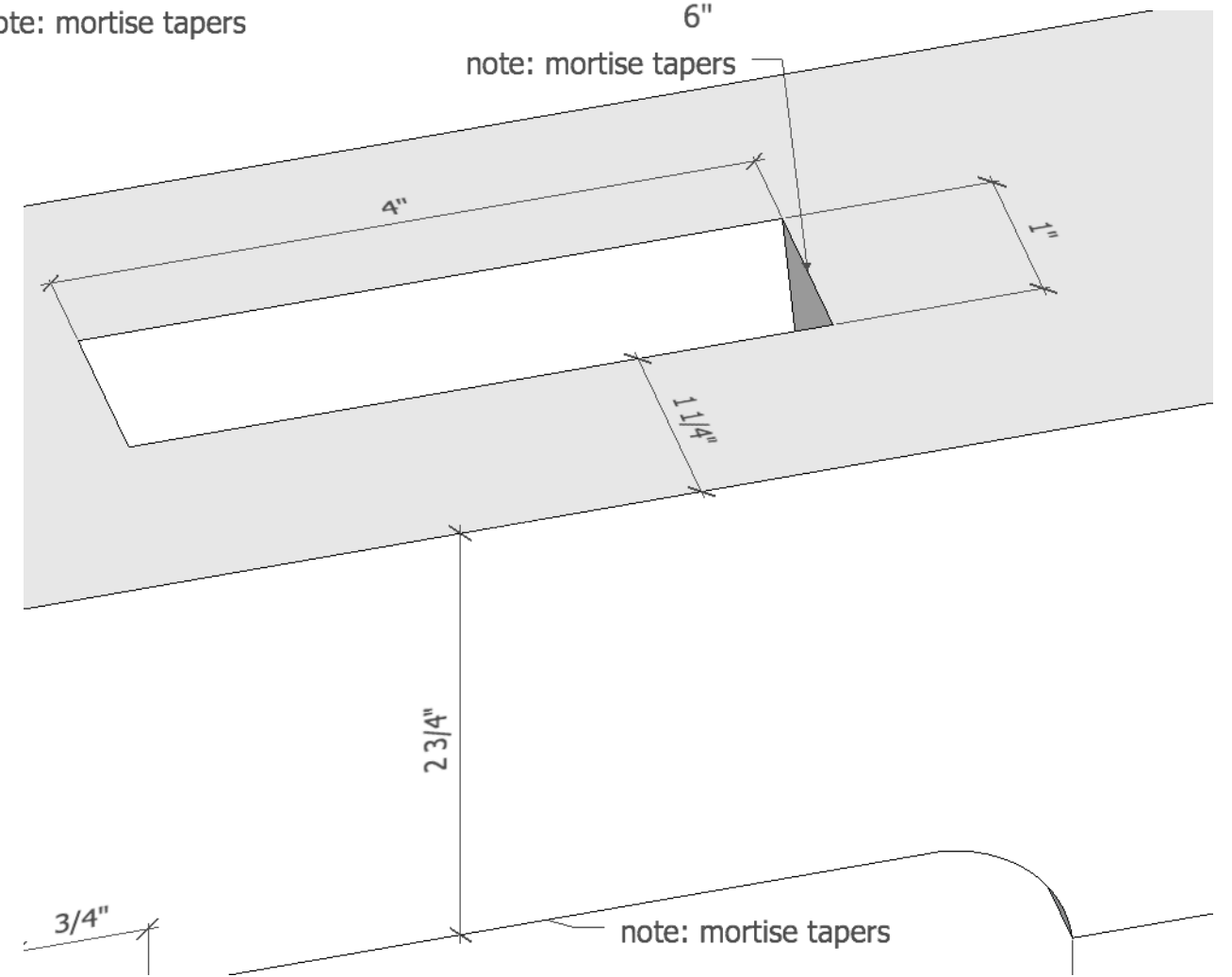
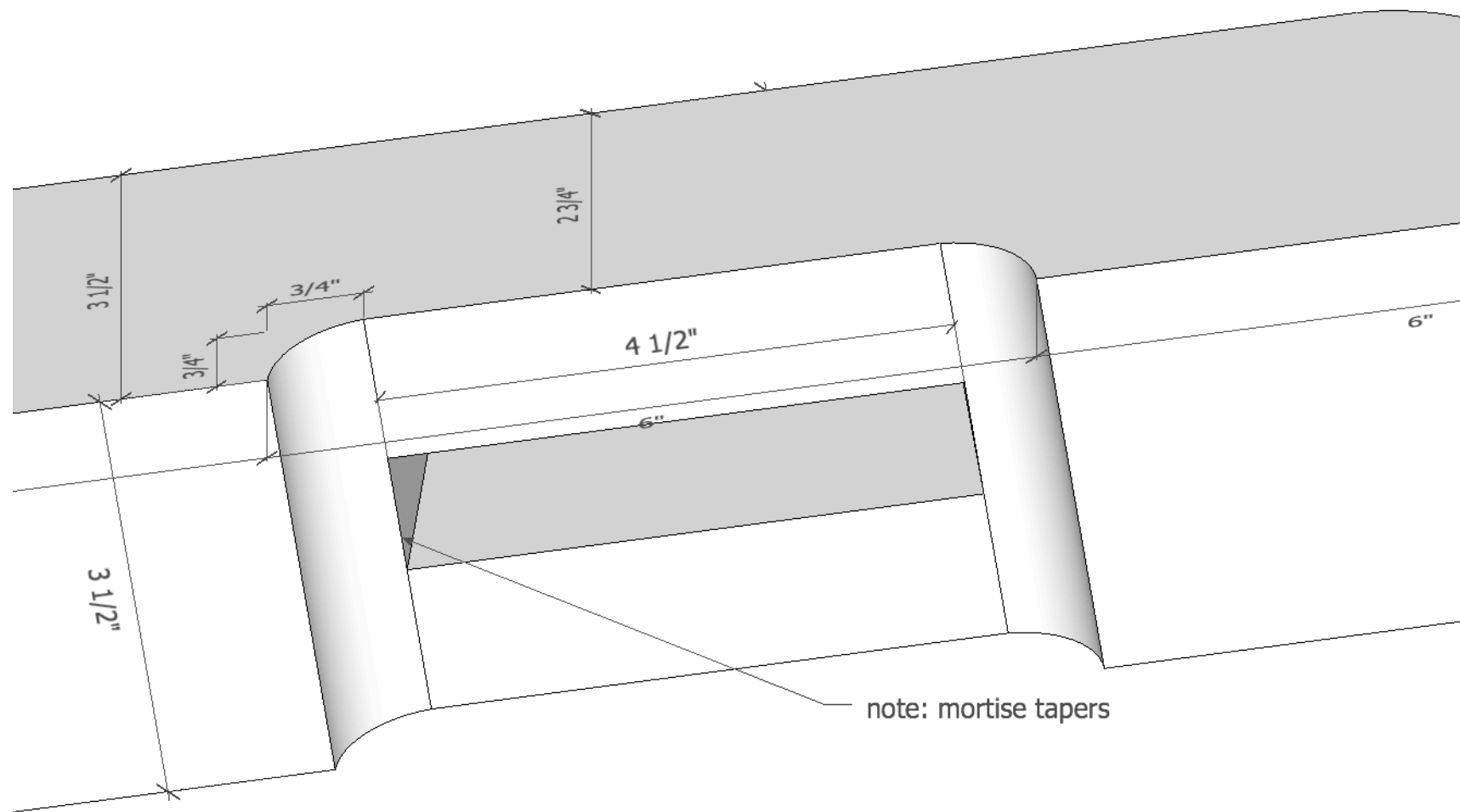
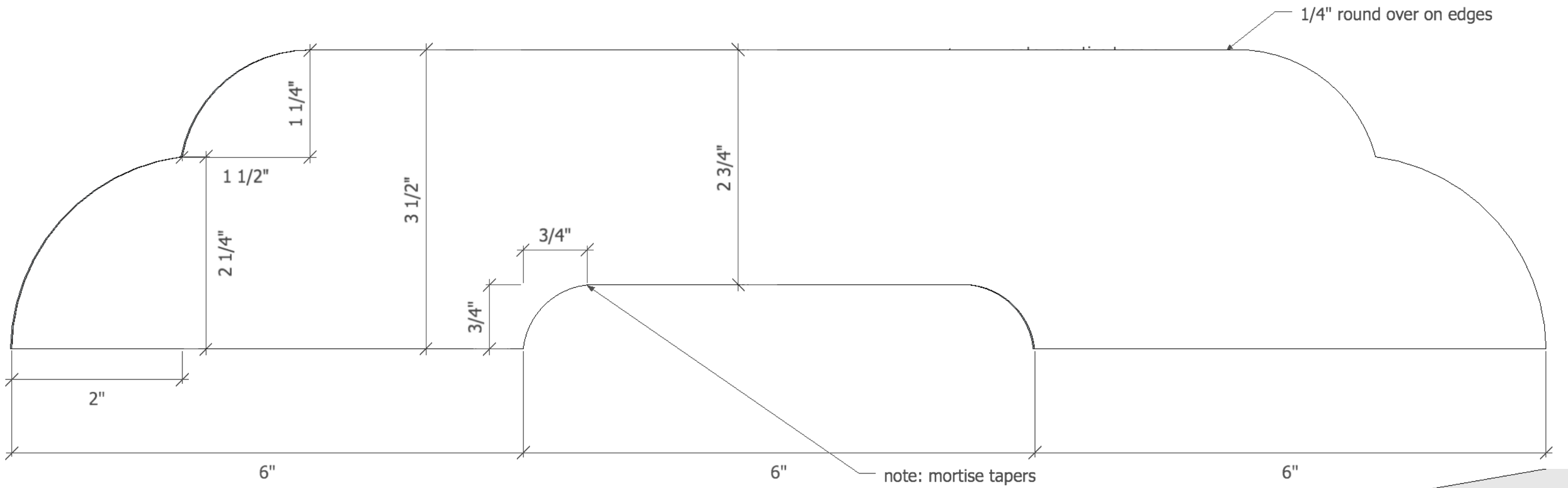

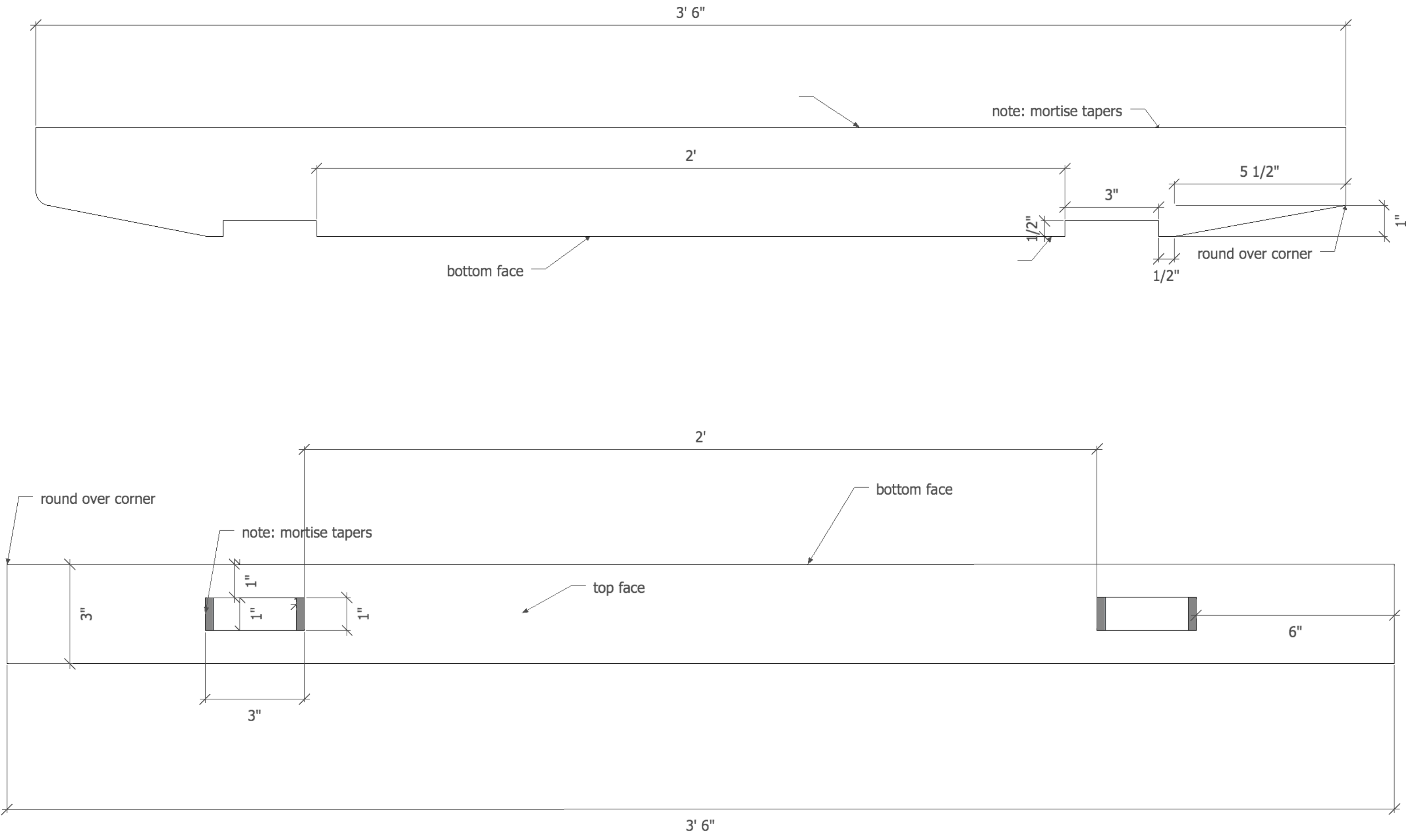

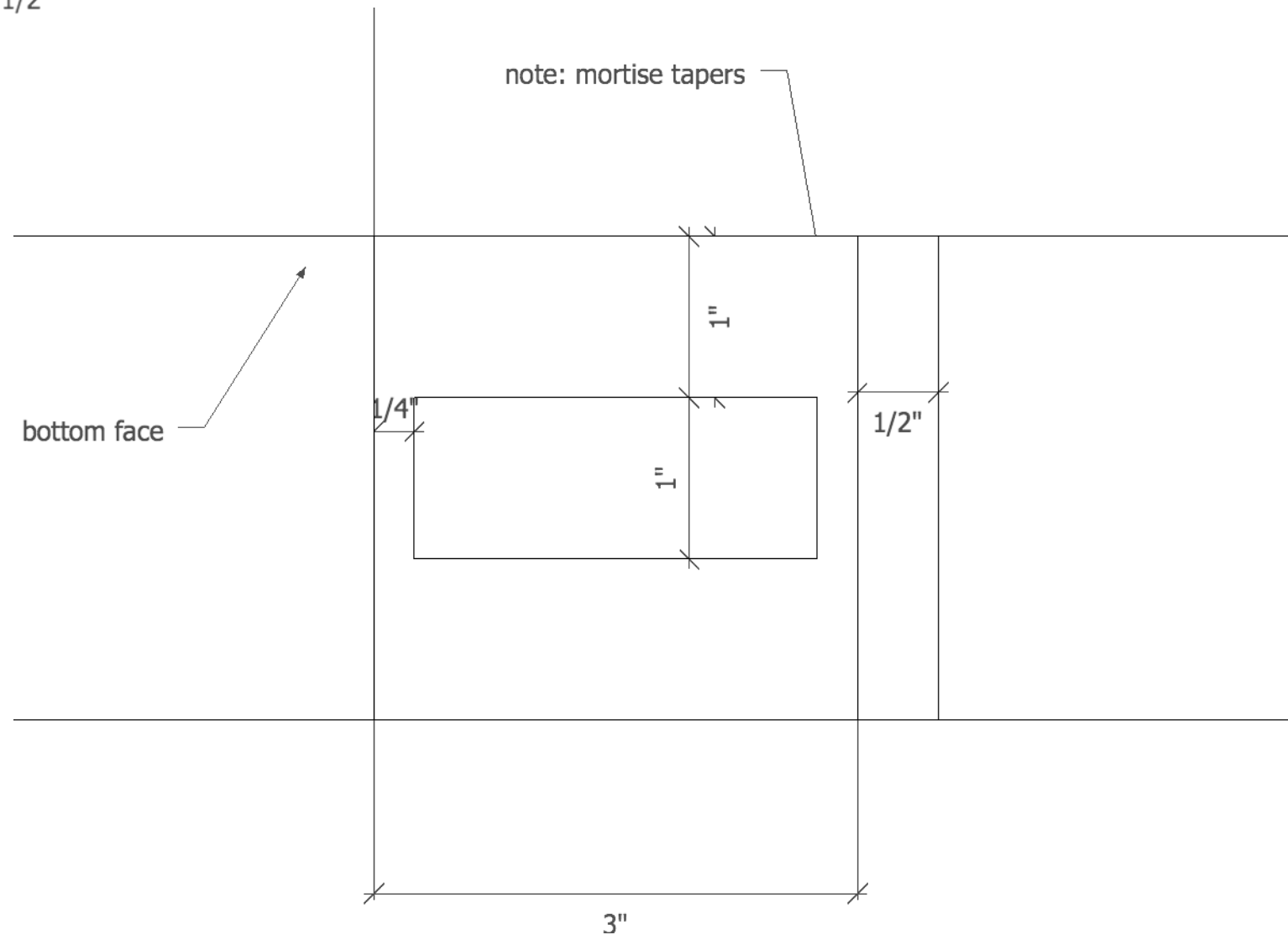
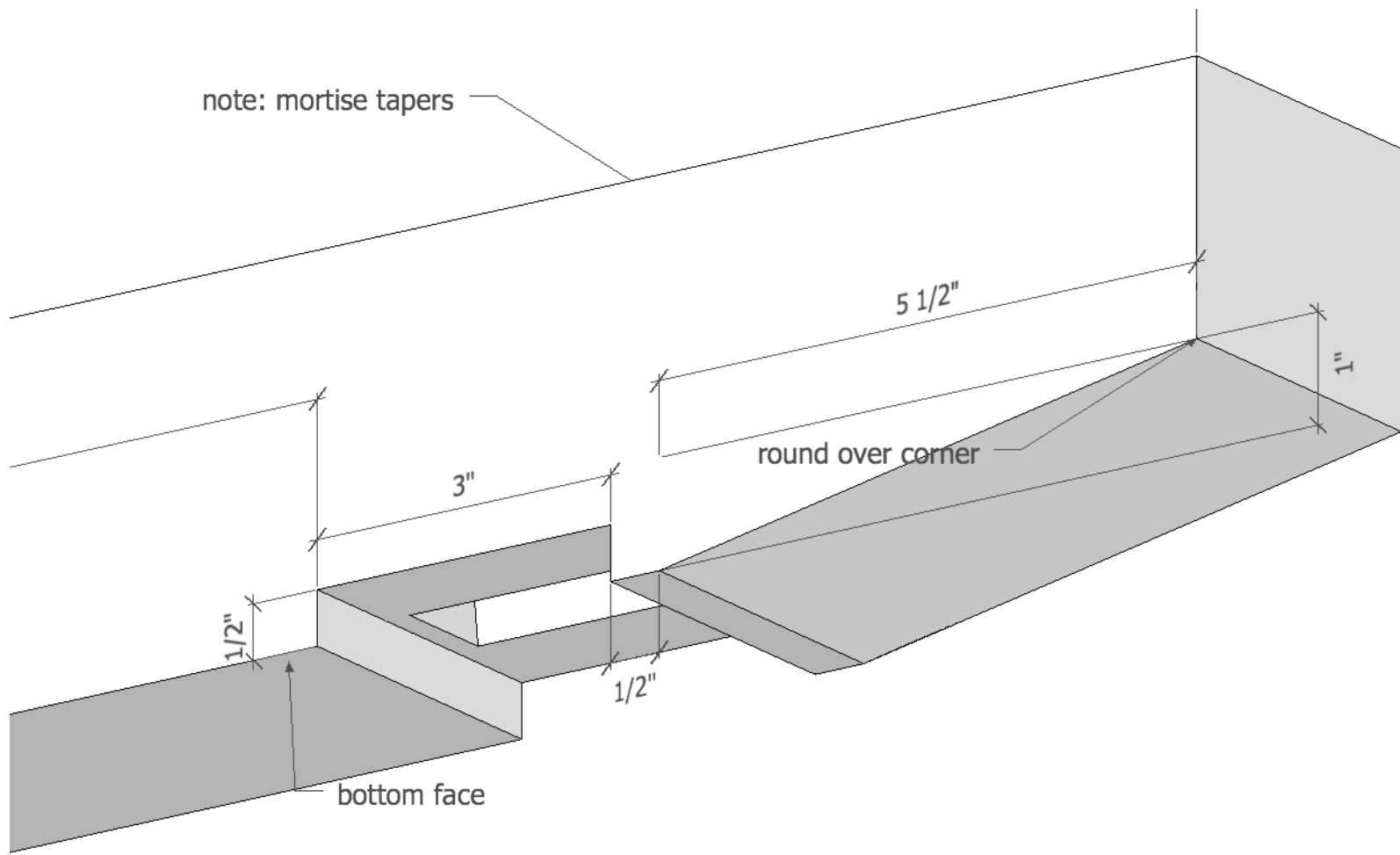
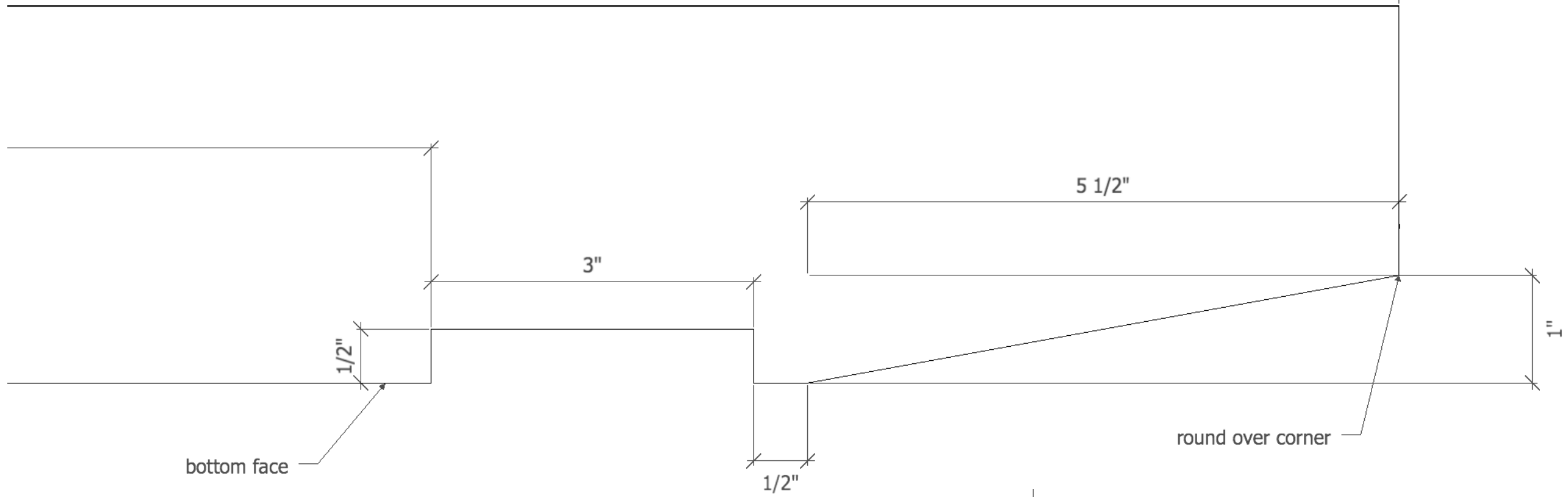

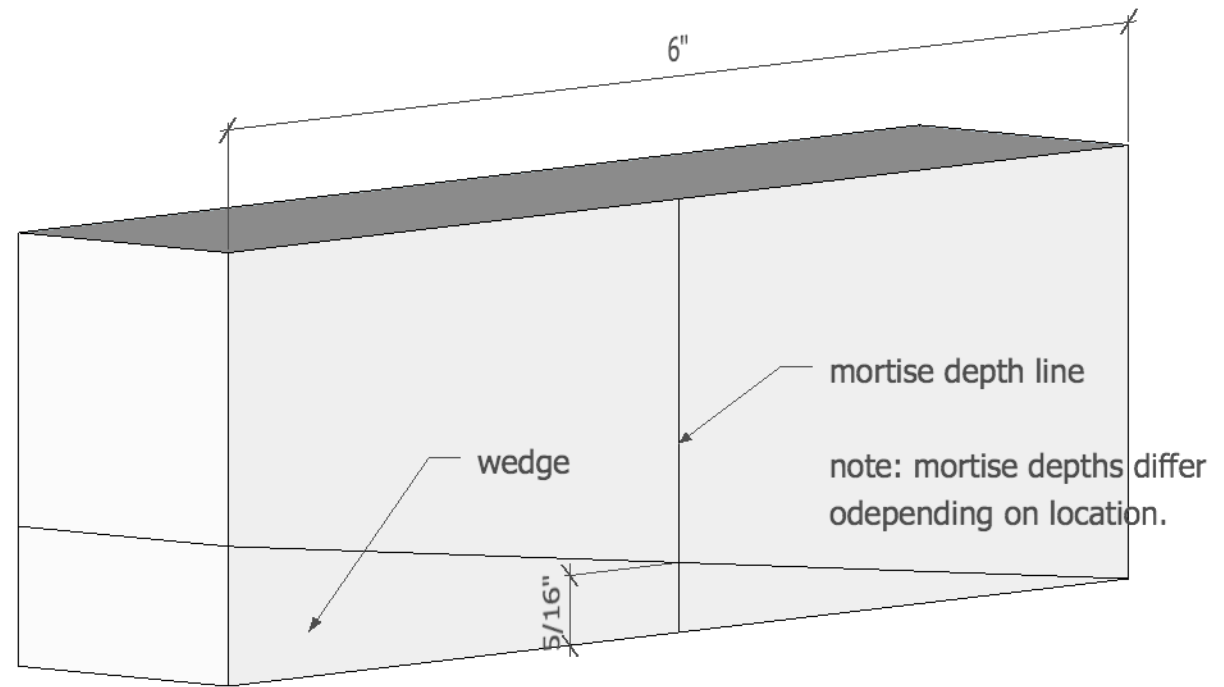
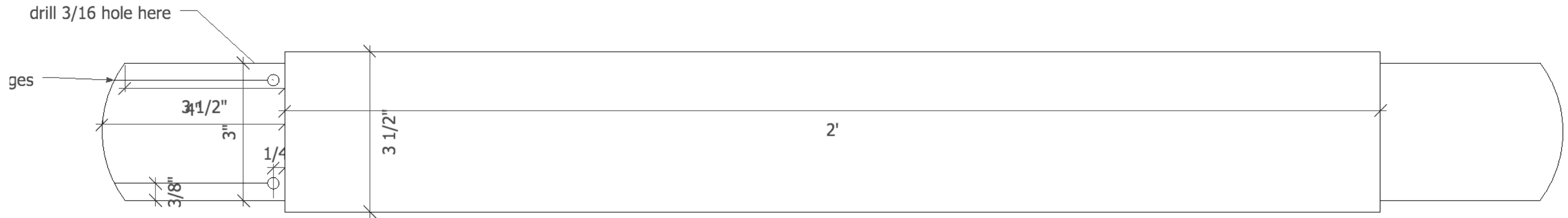

note: mortise depths differ depending on location.

note: cut wedges 2" longer than the tenon and taper from 0" to 5/16" over the depth of the mortise. example above.

